

Turbidity meter

Committed to process automation solutions

Datasheet



SUP-PTU100

SUP-PTU100 online turbidity / MLSS concentration analyzer is an intelligent online chemical analyzer, which is widely used for continuous monitoring of turbidity, MLSS concentration and temperature in such solutions as thermal power, chemical, fertilizer, metallurgical, environmental protection, pharmaceutical, biochemical solutions, food, and tap water.

Remote transmission monitoring and recording of continuous monitoring data is realized through the transmitting output connection recorder, and the monitoring and recording can also be realized by connecting the RS485 interface which can easily link it to computer through MODBUS - RTU protocol.

Technical Specification

Turbidity transmitter

Performance:

- Measurement: Turbidity, MLSS concentration
- Measuring range: 0.00~4000NTU, 0.00~120000mg/L
- Maximum loop resistance: 750 Ω
- Accuracy: 0.1%FS

Output Signal:

- Type of output: 4~20mA current transmitting output
- Type of output: RS485 digital signal output
- Communication protocol:
Standard MODBUS – RTU (Customizable)
- Alarm relay: AC250V, 3A

Other:

- Panel Front Size (mm) : 100(W) x 100(H) x Approx.150(D)
- Panel Cutout Size (mm): 92.5(W) x 92.5(H)
- Converter weight : Approx. 1 kg
- Display: LCD with back lights in English
- Color: Black
- Ambient temperature : -20 to +55°C (-5 - 130 °F).
- Storage temperature : -30 to +70°C (-20 - 160 °F).
- Humidity : 10 to 90% RH at 40°C (100 °F)



Turbidity sensor

Specification	Detailed Information
Size	D 60mm* L 256mm
Weight	1.65KG
Material	Body: PVC
	O-ring: Fluorine rubber
	Cable: PVC
Waterproof grade	IP68/NEMA6P
Measuring range	Turbidity:0.00 ~ 4000NTU/ MLSS concentration: 0.1 ~ 20000 mg/L, 0.1 ~ 45000 mg/L, 0.1 ~ 120000 mg/L
Display accuracy	Turbidity: Less than $\pm 2\%$ of the measured value or $\pm 0.1\text{NTU}$, whichever is larger / MLSS concentration: less than $\pm 5\%$ of the measured value (depending on the homogeneity of the MLSS)
Velocity of flow	$\leq 2.5\text{m/s}$, 8.2ft/s
Pressure range	$\leq 0.4\text{Mpa}$
Storage temperature	$-15 \sim 65^{\circ}\text{C}$
Ambient temperature for measurement	$0 \sim 45^{\circ}\text{C}$
Calibration	Calibration of sample, slope calibration
Cable length	10m standard cable, can be extended up to 100m



Outline dimension:

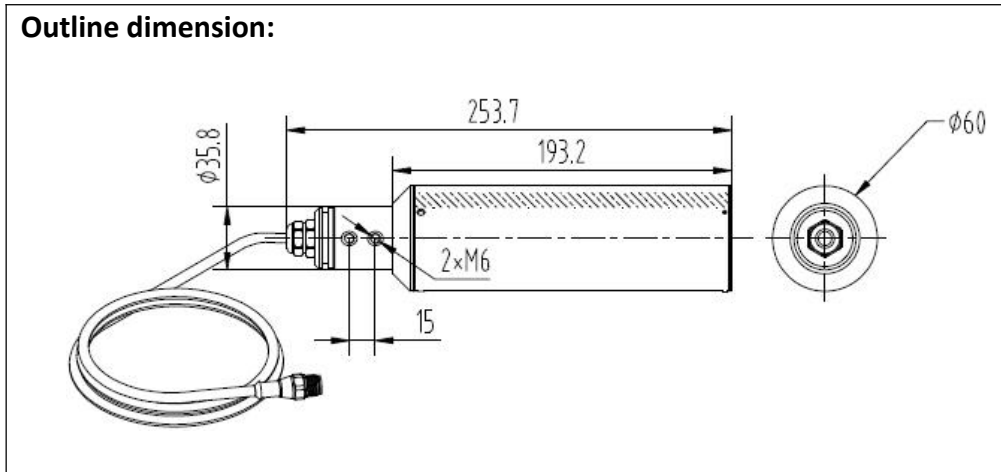

Features



- Using 2.8 inch 128*64 lattice screen
- Using isolated transmitting output, which has less interference
- Using isolated RS485 communication
- TUR/TLSS measurement, upper and lower limit control, transmitting output and RS485 communication can be made
- High and low alarm functions and retardation can be set
- The buzzer and LCD backlight switch on and off function
- Operation language selectable, English or Chinese
- Correction and calibration of are available

Description

The device is designed for use on site. A rugged housing protects the electronics and the electrical connections from corrosive environmental conditions . As an alternative, the device can also be installed in a control panel.



PUT100 turbidity meter

- 1, High alarm: High alarm
- 2, Low alarm: Low alarm
- 3,ESC: Check related warning status on the “monitoring page”
Return to previous level page in the up& down level page linked to “menu page”
- 4, Menu: Enter the MENU on the “monitoring page”
Exit the MENU on the “menu page”
- 5,   : “MOVE RIGHT” and “MOVE DOWN”
- 6, Enter: Enter the sub-menu or confirm modification on the “menu page”

Wiring

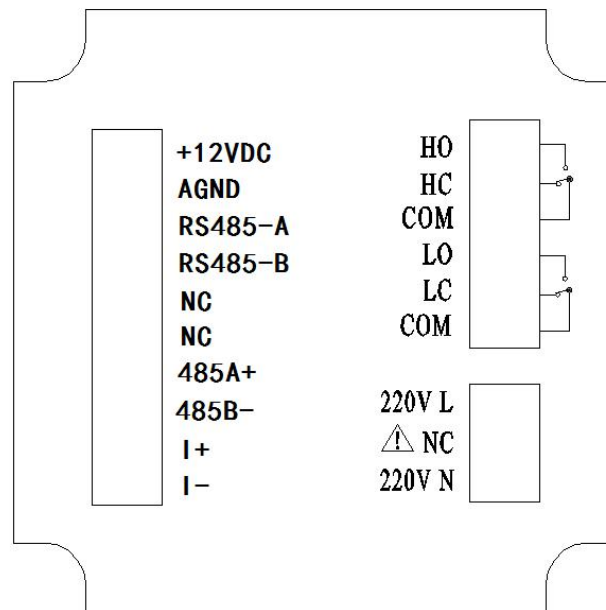

Wiring diagram

Identification of terminal

- AGND: Turbidity / MLSS concentration electrode power supply negative
- RS485-A: Turbidity / MLSS concentration electrode communication positive
- RS485-B: Turbidity / MLSS concentration electrode communication negative
- NC: null
- NC: null
- 485A+: RS485 communication output terminal A+
- 485B-: RS485 communication output terminal B-
- I+: 4-20mA output terminal +
- I-: 4-20mA output terminal -
- HO: High alarm normally open relay
- HC: High alarm normally closed relay
- COM: Common terminal
- LO: Low alarm normally open relay
- LC: Low alarm normally closed relay
- COM: Common terminal
- 220V L: AC220V live line
- NC: null
- 220V N: AC220V zero line

Display

Turbidity monitoring screen:

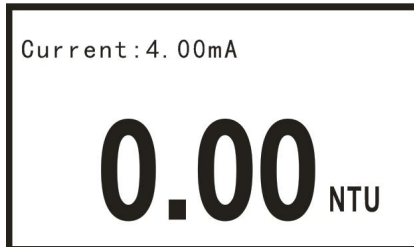

MLSS concentration monitoring screen:



Calibration

The Turbidity/MLSS concentration sensor has been calibrated before delivered, and the self calibration can be carried out according to the following steps if required. The use of standard liquid is required for the calibration of the MLSS concentration, taking two-point calibration as an example:

1. Connect the sensor to the transmitter.
2. Set up the related parameters (set the Turbidity/MLSS concentration factor as 1 in the signal setting), enter the Turbidity/MLSS Concentration Calibration actual value measurement interface and clean the sensor.
3. Put the probe into the first point standard liquid (usually take the pure water as the first point). After the data is stable, read the actual value of the measurement and record the data.
4. Remove the probe from the first point standard liquid, rinse it with clean water, and wipe dry the sensor.
5. Put the probe into the second point standard liquid. After the data is stable, read the actual value of the measurement and record the data.
6. Click OK after recording the data; enter the standard point selection interface and select the two-point calibration; enter the first point target value setting interface.
7. Enter the target value of the first point standard liquid measured at the laboratory and click OK; enter the first point actual value setting interface and then enter the first point actual value recorded in step 3; click OK to enter the second point target value interface.
8. Enter the target value of the second point standard liquid measured at the laboratory and click OK; enter the second point actual value setting interface and then enter the second point actual value recorded in step 3; click OK to return the main menu.

